

# ISO coulissante négative

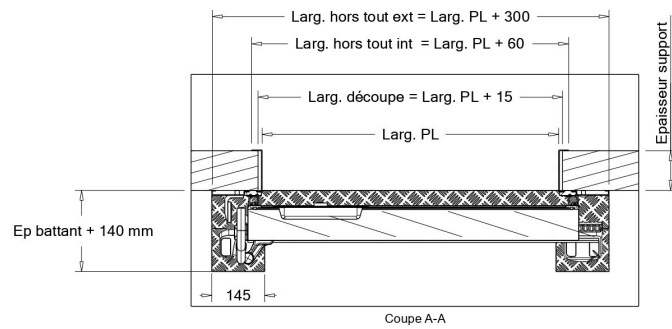
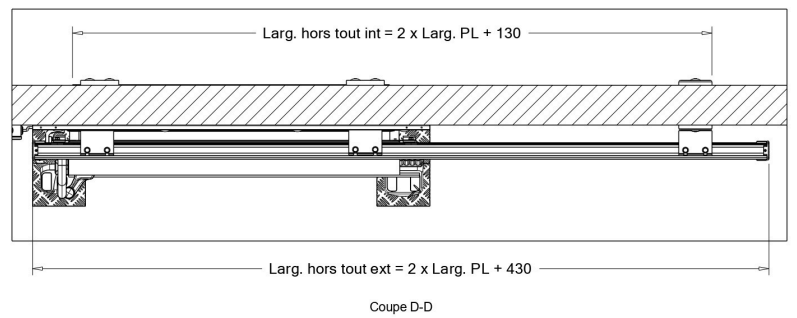
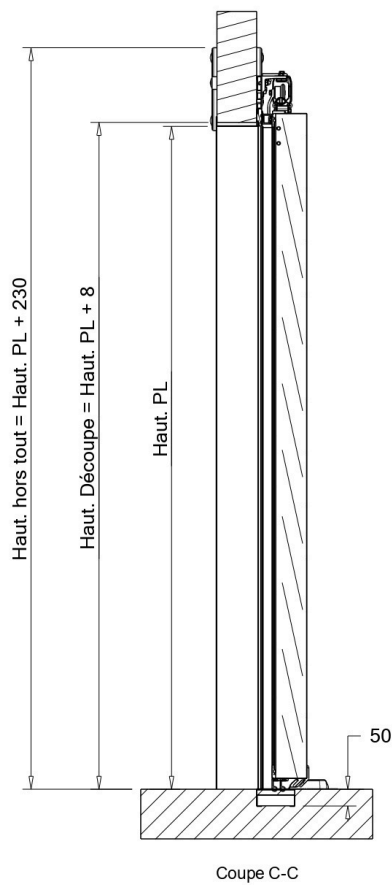
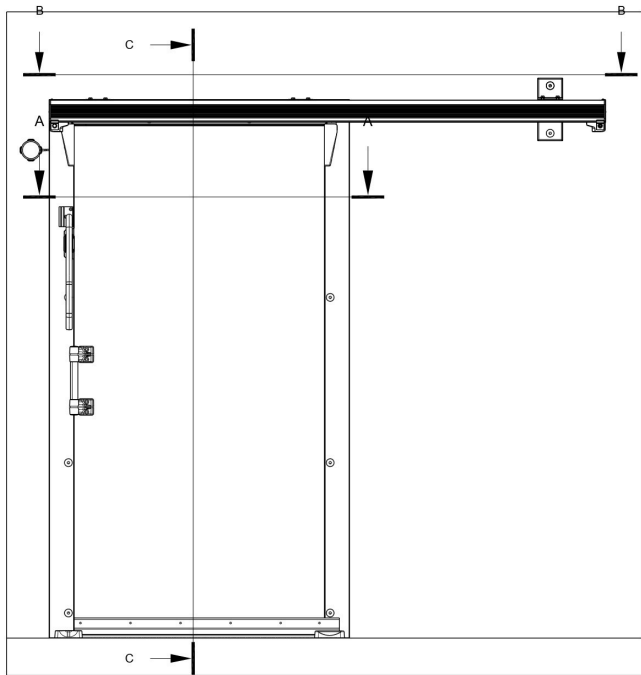

## Description de la porte

Matière	Epaisseur	Vé	Edition	Date	Page